

Fear of Leveling Choose Magician X

Innovator of Smart Leveling

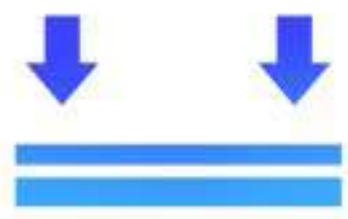



Free
Leveling



Double-Gears
Direct Extruder

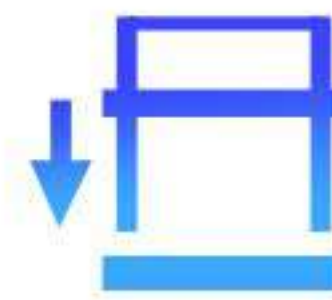

One Step
Assembled



Ultra-Silent
Printing



Belt
Tensioner



4th Gen Carborundum
Glass Platform



3.5" Colorful
Touch Screen



High accuracy
BabyStep



All-In-One
Design

Free Leveling



Manual Leveling
by Screws



More Intelligent
& Convenient



Traditional
BL/3D Touch

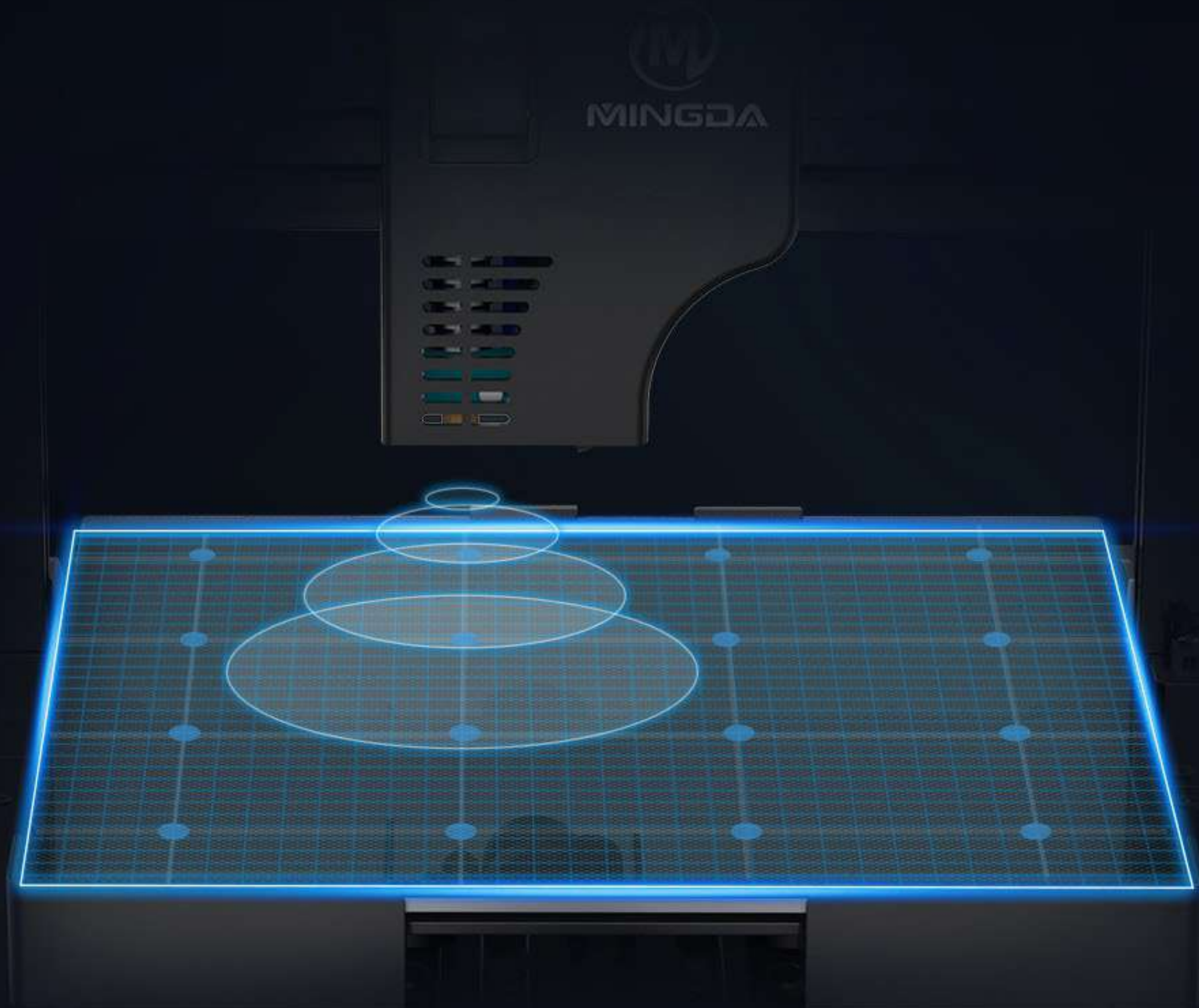

Ready to Print

99% pre-assembled. One step to assemble

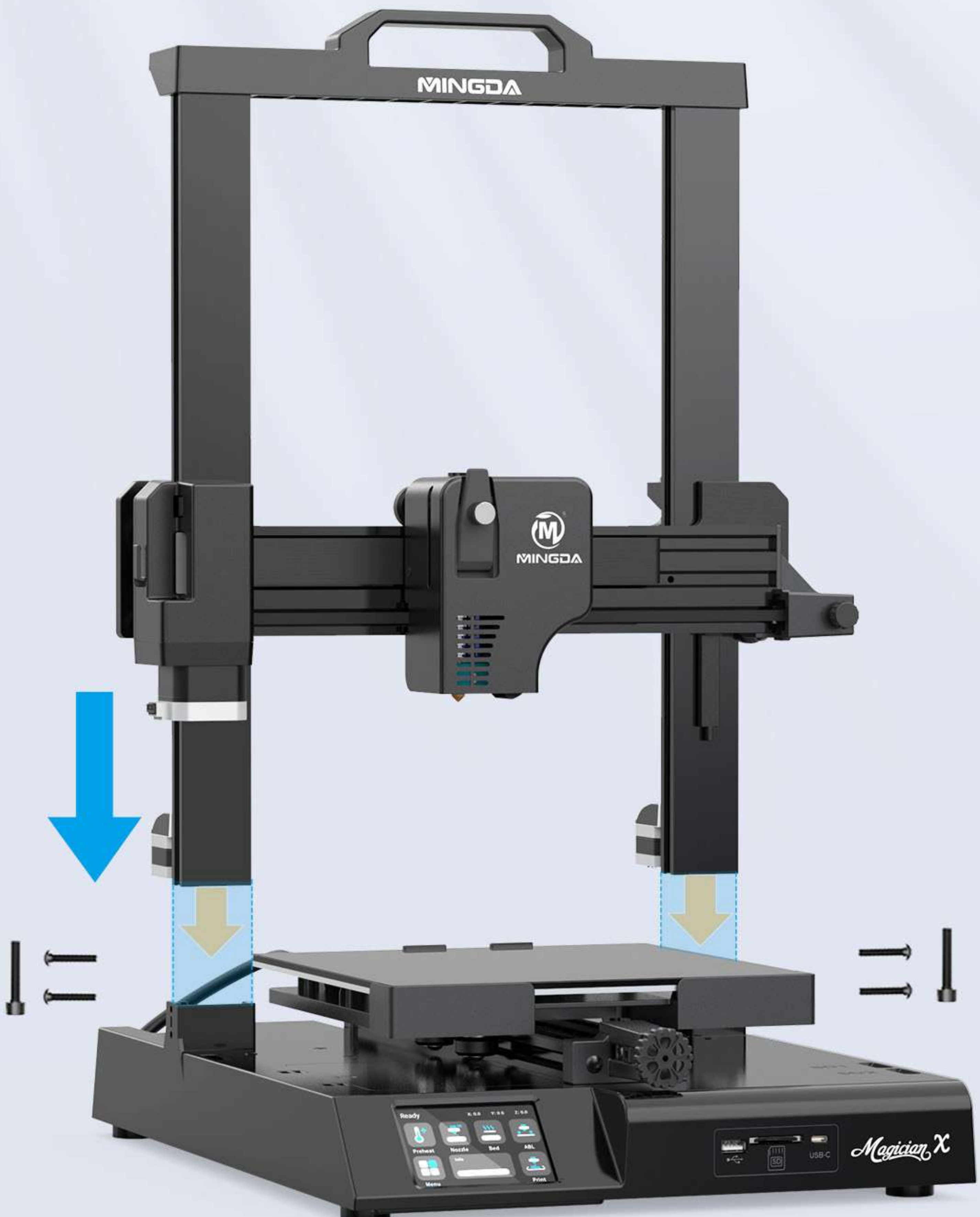

Double-Gears Direct Extruder



Double Gear
Extrusion Mechanism



Direct Drive



Modular Parts



Ultra-Silent Printing



TMC2209
Silent Drivers



Upgraded
Fans of Extruder



Modular
Mechanical Structure

