

# High Performance Tunable Laser TSL-710

The TSL-710 is Santec's flagship, highest performance tunable laser. Combining high output power with high signal-to-noise ratio makes the TSL-710 an invaluable tool for optical testing. An innovative external cavity design has been implemented to lower the optical ASE noise, leading to a high signal-to-noise ratio of over 90dB/0.1nm, while still maintaining a high output power of over +10dBm. The TSL-710 is also equipped with features such as fine-tuning and coherence control. GPIB interface with the industry standard SCPI command set allow full remote control and measurement automation.

The TSL-710 is an outstanding tool for testing next generation components for Dense Wavelength Division Multiplexing (DWDM) such as multi-input, high extinction ratio devices such as Wavelength Selective Switch (WSS). The TSL-710 has excellent wavelength characteristics with high wavelength accuracy of  $\pm 2\text{pm}$ , high wavelength resolution of 0.1pm, and narrow linewidth of <100kHz. These features make it suitable for cutting edge research in nanophotonics. The TSL-710 covers a wide tuning range of 160nm and is designed to improve production inspection throughput by doubling the scan repetition rate over conventional lasers. The laser linewidth is less than 100kHz, making it suitable to be used as a local oscillator in coherent transmission, as well as a tool for interferometry and sensing applications. In addition, the TSL-710 is available for WDL and PDL measurement with support of our dedicated software engineers.



## Measurement Data

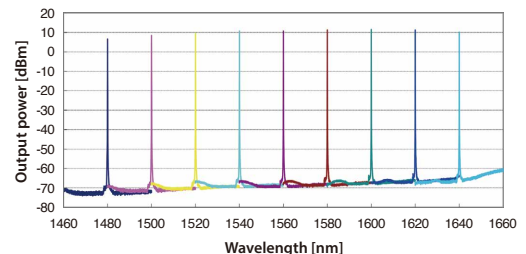

## Features

- ▶ Wide Wavelength Range from 1480 to 1640 nm (SCL-Band)
- ▶ High Wavelength Accuracy:  $\pm 2\text{ pm}$
- ▶ Wavelength Resolution: 0.1 pm
- ▶ High Output Power: 10 dBm
- ▶ High Signal-to-Noise Ratio: 90 dB/0.1 nm
- ▶ Narrow Linewidth: 100 kHz

## Applications

- ▶ Optical component characterization
- ▶ Fiber optic transmission testing
- ▶ Photonic material characterization
- ▶ Interferometry
- ▶ Optical spectroscopy

# SANTEC TUNABLE LASERS

## Specifications

Category	Parameter		Unit	Performance
				High power & Low Noise
Wavelength Characteristics	Wavelength Tuning Range		nm	1480-1640 (160nm)
	Wavelength Setting Resolution		pm	0.1
	Absolute Accuracy *1	Operating Temperature	pm	±2
		25±1°C (typ.)	pm	±1
	Repeatability *1		pm	±1
	Stability (typ.) *2		pm	±1
Sweep Speed		nm/sec	0.5 to 100	
Optical Power Characteristics	Output Power	Peak (typ.)	dBm	≥ 13
		1500-1630nm	dBm	≥ 10
		Full Tuning Range	dBm	≥ 7
	Power Repeatability *1, *3		dB	±0.01
	Power Stability *2, *3		dB	±0.01
	Power Flatness vs. Wavelength *1, *3		dB	±0.2
Relative Intensity Noise (RIN) (typ.)		dB/Hz	-145 *6	
Spectrum	Linewidth (typ.)	Coherence Ctrl. Off	kHz	100
		Coherence Ctrl. On	MHz	40
	SMSR (typ.)		dB	≥ 45
	Signal to Total Source Spontaneous Emission Ratio *4		dB	≥ 70
	Signal to Source Spontaneous Emission Ratio *5		dB/nm	≥ 80 (≥ 90 dB/0.1nm)
Interface	Optical Output Connector		-	FC or SC, SPC or APC
	Optical Fiber		-	SMF or PMF *7
	Communication		-	GP-IB (IEEE 488.2), USB, RS-232C
	Power Monitor		V	0 to 3
Modulation	LF Modulation		kHz	DC to 400 (Input level -2 to 0V, Modulation depth >50%/V (typ.))
	RF Modulation (option)		MHz	2 to 100 (Input level 5Vp-p, Modulation depth >10% (typ.))
Environmental Conditions and others	Operating	Temperature	°C	15 to 35
		Humidity	%	< 80 (non-condensing)
	Power Supply		-	AC 100-240V±10%, 50/60Hz
	Power Consumption		VA	100
	Dimensions (W) x (D) x (H)		mm	210x440x110
Weight		kg	6.5	

\* All specifications are quoted after 1 hour warm-up period. Specifications apply for wavelengths not equal to any water absorption line.

\*1: At static condition or "Step" sweep mode. \*2: For period of 1 hour. Within ± 0.5 °C. \*3: At "Auto" power mode.

\*4: Ratio of signal power to total spontaneous emission power within ±15nm of the signal wavelength (typical value).

\*5: Ratio of signal power to maximum spontaneous emission power in a 1nm band within a ±3nm band around the signal wavelength (typical value).

\*6: Measured Freq. 1MHz to 3GHz

\*7: In case of PMF, polarization axis in alignment with connector key. Polarization extinction ratio is 17dB (typical value).

## Laser safety information



This product is classified class 1M laser product according to IEC 60825-1 (2007).

This product complies with FDA performance standards for laser products except for deviations pursuant to Laser Notice No. 50 dated June 24, 2007.

## Ordering Code

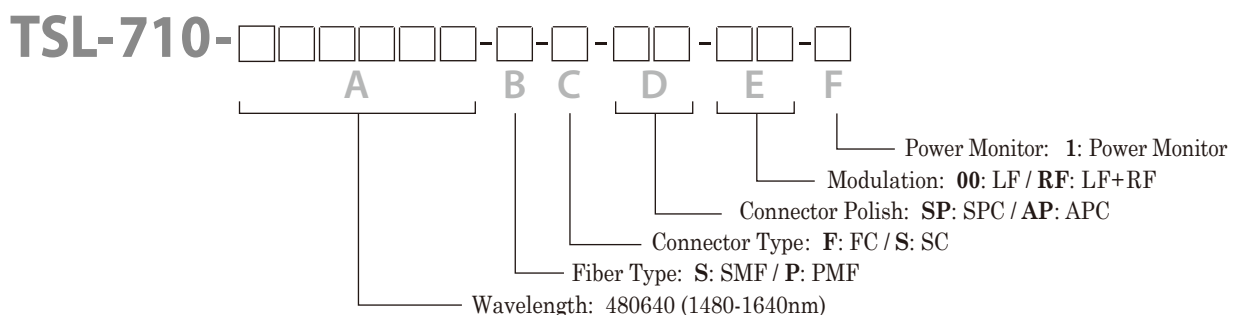

[www.santec.com](http://www.santec.com) E-Mail : [sales@santec.com](mailto:sales@santec.com)



### SANTEC CORPORATION

5823 Ohkusa-Nenjozaka, Komaki, Aichi 485-0802, Japan Tel. +81-568-79-3536 Fax +81-568-79-1718

### SANTEC U.S.A. CORPORATION

433 Hackensack Ave., Hackensack, NJ, 07601, U.S.A. Toll Free +1-800-726-8321 (santec-1) Tel. +1-201-488-5505 Fax +1-201-488-7702

### SANTEC EUROPE LIMITED

Grand Union Studios, 332 Ladbroke Grove, London W10 5AD, U.K. Tel. +44-20-3176-1550

### SANTEC (SHANGHAI) Co., Ltd.

11F Room E, Hua Du Bldg., No.838 Zhangyang Road, Pudong District, Shanghai 200122 China Tel: +86-21-58361261, +86-21-58361262 Fax: +86-21-58361263